

MPT-250B-SC SPECIFICATIONS AND OPERATING INSTRUCTIONS

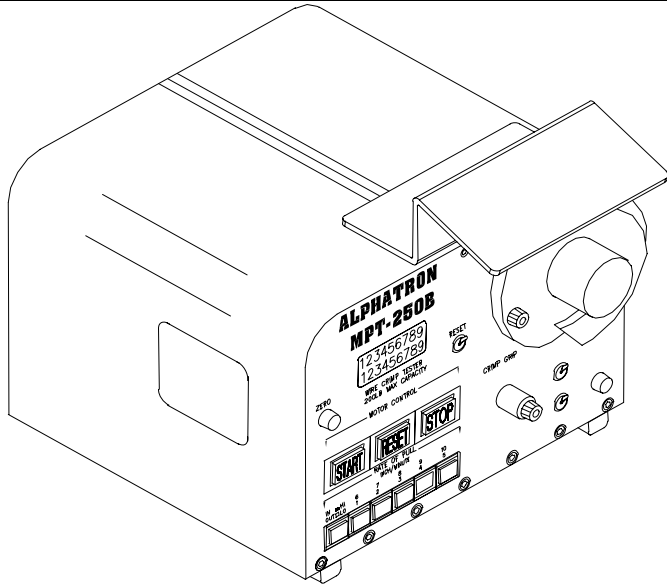

DATASHEET



MPT-250B-SC SAFE-T-CABLE PULL TESTER

SPECIFICATIONS

PERFORMANCE

Capacity: 250lb (90.7kg) (890N)
Safe Overload: 150% of capacity
Readout Accuracy: $\pm 0.5\%$
Resolution: 0.1lb
Speed Control Accuracy: $\pm 1/8"/\text{min}$ @ 1-5"/min rate of pull
 $\pm 1/4"/\text{min}$ @ 6-10"/min rate of pull
Standard Display: Pound, Kilogram, or Newton Units (XXX.X)
Operating Temperature: 50°F to 100°F (10°C to 38°C)
Auto-Stop: Selectable to be enabled or disabled
Data Output: RS232

PHYSICAL

Weight: 26lb, less options
Height: 8in
Width: 10in
Depth: 15in
Cabinet: Painted Carbon Steel

ELECTRICAL

Standard Power: 115VAC, 50/60Hz

OPTIONAL FEATURES AND ACCESSORIES

Special motor speed rates available
Adjustable set point for motor stop at preset force and Constant Force Pull
Optional Power: 230VAC, 50/60Hz

1. SAFETY

The MPT-250B-SC Safe-T-Cable® motorized Pull Tester is a force measurement device, and as such should be operated with due caution. Operators should wear safety glasses for eye protection because the crimp under test may break suddenly and fragments may fly off.

Do not overload: The gear motor in the pull tester can exceed the load limits of the load cell component in this device. For your protection the MPT-250B-SC has been factory set to stop if the peak force exceeds 250lb. The unit is set to automatically stop at readings above 249.9lb.

2. SETUP

The MPT-250B-SC is designed to perform pull-off testing of .020, .032, .040 and .062 diameter sizes of Safe-T-Cable® to verify compliance requirements of SAE Aerospace Standard AS4536A.

The Alphasatron MPT-250B-SC is shipped from the factory pre-calibrated and tested. To assure consistent, correct results, users should familiarize themselves with the setup and operation of the unit before placing it in service.

To operate, set the MPT-250B-SC on a flat, level surface in an upright position. The unit can be tilted with the adjustable front feet to ease operator viewing of the display. Do not handle, pick up or move the unit by exerting leverage against any front or rear panel controls, fixtures or connections. Always lift by the base plate, preferably at the mid-point along either side. DO NOT use the lower 12-pt screw as a handle for lifting or moving the MPT-250B-SC. This can result in permanent damage to the load cell sensing unit.

3. PULL OFF LOAD TEST PROCEDURE (INDENTER TESTING)

- 3.1 Turn on the unit and allow it to warm up for 1 minute.
- 3.2 Set the rate of pull selector to 2 inches per minute.
- 3.3 Adjust the zero knob to zero the display if needed. Unit will automatically check calibration.
- 3.4 Push the yellow RESET button to return the pull wheel to the starting position as shown in Figure 1.
- 3.5 Thread the cable through the 12-point screws as shown in Figure 1, and terminate the cable with the appropriate Safe-T-Cable tool®.

Daniels Manufacturing Corporation, 526 Thorpe Road, Orlando, FL 32824, U.S.A.

Phone: (407) 855-6161 ° Fax (407) 855-6884 ° www.dmctools.com ° Email: dmc@dmctools.com

3.6 Push the green START button to begin the test. When the sample breaks, push the red STOP

button if the unit has not been stopped by the Auto-Stop feature.

4.1 Adjust the zero knob to zero the display if necessary. The unit will automatically check calibration.

4.2 Thread the cable through the 12-point screws as shown in Figure 1, and terminate the cable with

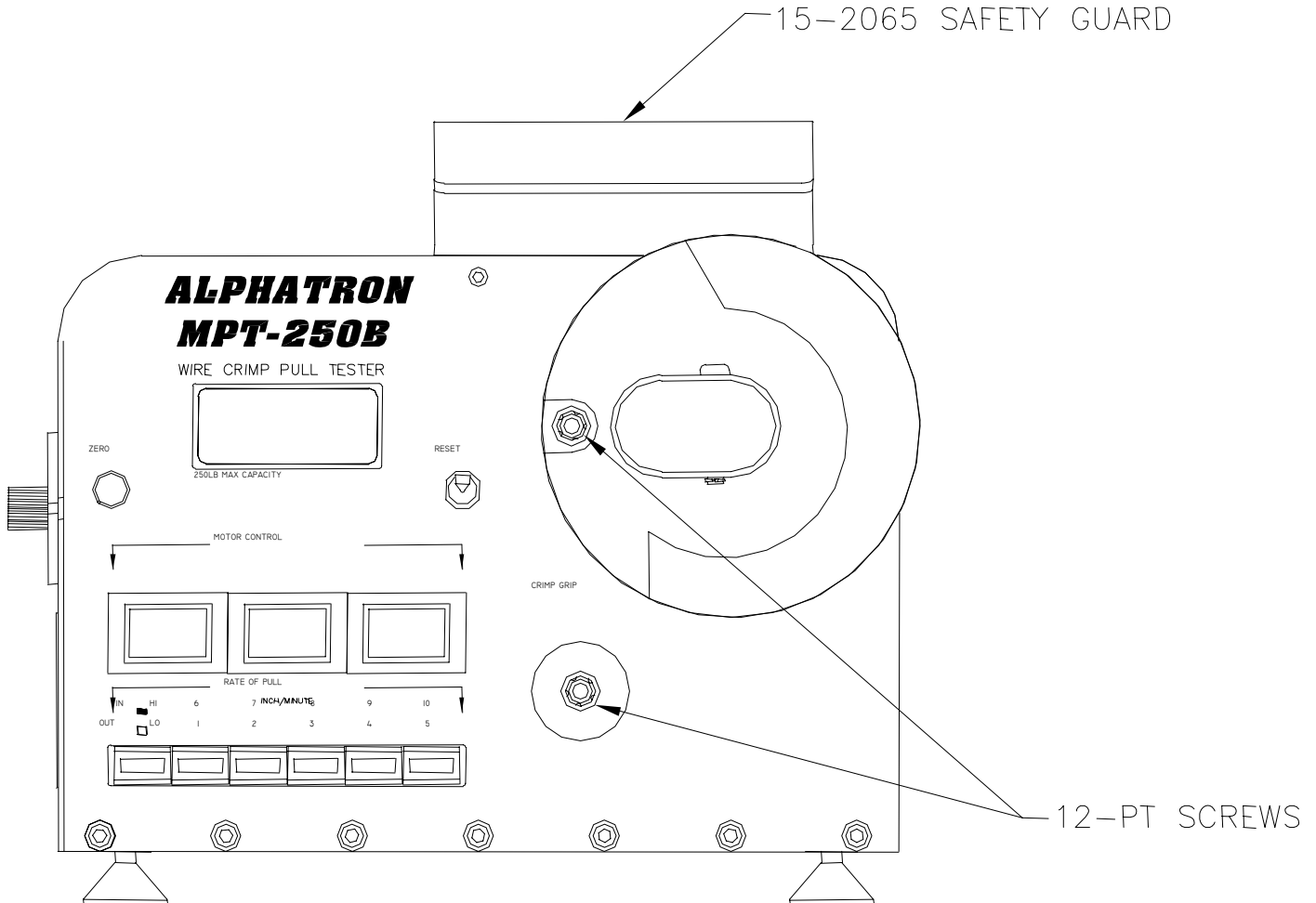

FIGURE 1

3.7 Record the results of the test. Remove the sample from the 12-point screws and push the yellow RESET button to return the pull wheel to the starting position in preparation for the next sample.

3.8 Adjust the indenter of the Safe-T-Cable® application tool if the maximum load sustained by the cable sample is less than the minimum pull off strength specified in AS4536A (see chart on page 5).

4. APPLIED TENSION TEST PROCEDURE

Use the MPT-250B-SC tensile tester to perform the tension/yield testing of Safe-T-Cable®.

the appropriate Safe-T-Cable® tool.

4.3 Open the tool handles, and remove the tool from the end of the cable. The display will indicate the highest reading during the installation of the cable. This reading is only an in process tension reading.

4.4 With the cable assembly suspended between the two 12-pt screws, press the RESET toggle switch (located to the right of the display) on the front panel. The display now reads the exact installed cable tension.

4.5 Verify the correct rate of pull (2 inches per minute), and activate the START motor control.

Continue in the START mode until the cable assembly breaks. The unit will operate until the

STOP button is pushed (unless the AUTO-STOP is enabled). The highest force achieved during testing will remain on the display until the unit is reset.

5. FRONT PANEL CONTROLS

5.1 MOTOR CONTROLS

NOTE: PRESS AND HOLD SWITCHES FOR APPROXIMATELY 1 SECOND TO ALLOW FOR PROPER ACTIVATION

START-Motor start switch to begin test.

RESET-resets display meter to zero, and resets pull wheel to START position for the next test. Reset must be performed after each test.

STOP- Stops the motor and the meter retains the current peak value.

5.2 RATE OF PULL CONTROLS

LO-HI SWITCH

LO (Green)-selects rate of pull of 1-5 in/min.

HI (Yellow)-selects rate of pull of 6-10 in/min.

NUMBERED RATE SWITCHES

Select the rate of pull, 1-5 in/min (LO-Green), or 6-10 in/min (HI-Yellow) as chosen by setting of LO-HI switch.

5.3 DISPLAY CONTROLS

ZERO – Adjusts the display to true zero. When turned counterclockwise the meter reading will decrease. When turned clockwise the meter reading will increase. The display will be checked for zero adjustments at startup and after each test when the RESET switch is pressed.

5.3 OPTIONAL CONTROLS ON THE FRONT PLATE

5.3.1 – The SETPOINT option enables an operator to set the force at which the MPT-250B-SC is to stop automatically if the test

proceeds to that force and the connection under test does not fail.

When the SETPOINT/MEASURE switch is held in the MEASURE position it enables the operator to select the set point by turning the SET adjusting knob next to the switch. As the knob is turned, the set point force will be indicated on the display meter. Clockwise adjustment increases the set point value, and turning the knob counterclockwise decreases the value. The force reading from the load cell is disabled, and will not be enabled until the switch is in the SETPOINT (raised) position. Tests are conducted with the switch in the raised

position. When the load reaches the set point level, the motor will stop and the unit can be reset and reloaded for the next test.

This option can be used in conjunction with the AUTO STOP (4.6.6) feature. When

both features are turned on, the test will stop automatically if either condition is met (AUTO STOP, or SETPOINT).

If the peak reading of the force necessary to part a connection is desired, the set point should be at 249.9lb before testing.

5.3.2 – The CONSTANT FORCE option operates similarly to the SETPOINT option.

The difference being that when the set point value is reached the connection is held at that load, instead of the test stopping. An additional switch is provided above the SET knob. The switch should be set to PEAK for normal operation, and to CONTINUOUS when using the CONSTANT FORCE option.

5.4 SPECIAL FEATURES

5.4.1 RS-232 DIGITAL OUTPUT

The MPT-250B-SC is shipped from the factory with RS-232 output installed. It is configured with all required communication parameters preset to the most common settings.

5.4.2 RS-232 SPECIFICATIONS

Communications System: Full Duplex
 Baud Rate: 9600
 Data Bits: 8
 Stop Bits: 1
 Parity: None
 Coding: ASCII

5.4.3 RS-232 CONNECTION

Pin Out: DB9
 Pin 2: (Rx) Receive
 Pin 3: (Tx) Transmit
 Pin 5: Signal Ground

5.4.4 RS-232 DATA FORMAT

Output from the RS-232 port will mirror the messages and data displayed on the LCD Display.

Example: System Power Up

Alphatron Warming Up
 S/N# XXXXXX
 Adjust Zero

Data Stream XXX.X-----XXX.X
 Calibrating
 XXX.X (Random R-cal value)
 Calibration OK
 Test in Process

Data Stream XXX.X-----XXX.X
 Stop

5.4.5 DIP SWITCH SETTINGS

The dip switches are accessed through the opening on the left side of the MPT-250B-SC. The access opening is covered with a plate that can be swung out of the way. Turn the large captivated screw counter clockwise until it comes loose from the side cover. The label below the cover depicts the switch banks and lists the switch

functions. The detailed description of the switch settings is as follows:

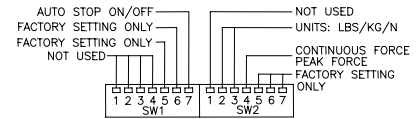

Bank SW1 (Toward rear of tester)

Switch 1: Not Used
 Switch 2: Not Used
 Switch 3: Not Used
 Switch 4: Not Used

Switch 5: Factory Setting DO NOT adjust.

Switch 6: Factory Setting DO NOT adjust.

Switch 7: Auto Stop Down=Off
 Up=On

Bank SW2 (Toward front of tester)

Switch 1: Not Used

Switch 2: lb units Down
 (Section 4.7) Kg units Up
 N units Up

Switch 3: lb units Up
 (Section 4.7) Kg units Down
 N units Up

Switch 4: Continuous Up
 Peak Down

Switch 5: Factory Setting DO NOT adjust.

Switch 6: Factory Setting DO NOT adjust.

Switch 7: Factory Setting DO NOT adjust.

NOTE: Switches 5, 6, & 7 are factory settings. Do not change from positions shown.

NOTE: The unit must be turned off, and then back on for dip switch changes to take effect.

5.4.6 AUTO STOP

This feature stops the pull test when the piece under test fails. When the force applied to the piece drops below 70% of the displayed reading, the test is completed and the unit stops. This feature is turned on or off using switch 7 of dip switch bank SW1.

ON=AUTO STOP works.

OFF=AUTO STOP disabled (the STOP switch must be used at the completion of a test).

NOTE: The AUTOSTOP function will not operate if the test range is at or below approximately 1.5lb. This is necessary to allow for the preload that an operator will normally apply when inserting a connector for the test. If the preload is greater than the lower limit, the unit will not start. In this case depress the reset toggle switch next to the display to be able to begin test.

5.5 POUND, KILOGRAM NEWTON SWITCHING

Dip switch 2 & 3 control the type of units that are measured by the tester. If pounds

are desired switch 2 is down and switch 3 is up. If kilograms are desired switch 2 is up and switch 3 is down. If Newton units are

desired both switch 2 and 3 are up. Cycle the units power off and back after changing any of these settings.

5.6 ATTACHING THE SAFETY GUARD 15-2065

The 15-2065 safety guard is designed to be attached to the top of the MPT-250B-SC via pressure sensitive adhesive that is attached to the underside of the part (see figure 2). Peel the paper cover from the adhesive and place the guard on the top cover of the tester as shown in figure 3. Make sure that the guard is positioned in the proper location in order to deflect any debris that may occur when pull testing any size of the Safe-T-Cable.

**CAUTION: DO NOT OPERATE THE
TESTER WITHOUT WEARING SAFETY
GLASSES! IF THE 15-2065 SAFETY
GUARD BECOMES DAMAGED,
CONTACT THE FACTORY FOR A
REPLACEMENT!**

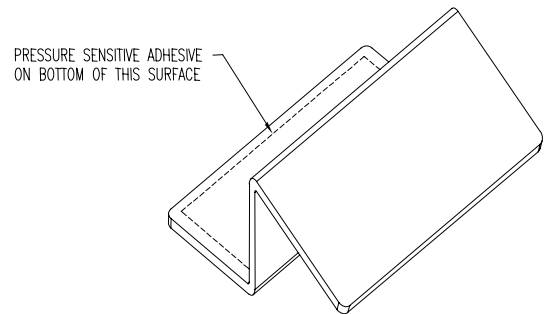

FIGURE 2

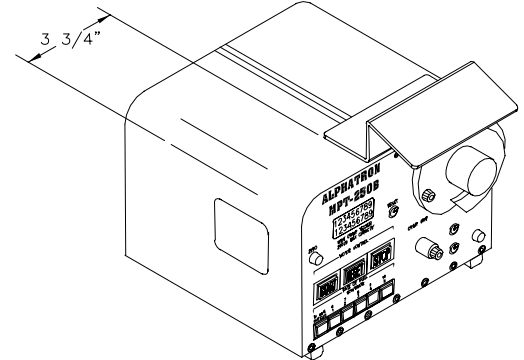

FIGURE 3

5.7 FUSE

If the main fuse requires replacement install a .3 Amp 125/250V slow blow fuse. The fuse compartment is located on the back of the unit and labeled as FUSE.

5.8 CALIBRATION

The MPT-250B wire crimp pull tester is factory calibrated with equipment traceable to the NIST. It is recommended practice to return the unit to DMC for calibration. In order to maintain traceability to NIST, do not exceed 12 months between factory calibration intervals.

The internal calibration test sequence is a reliable verification that the tester is accurate, but it does not assure traceability to NIST.

**LIMITATION OF LIABILITY/LIMITED
WARRANTY***

DANIELS MANUFACTURING CORPORATION IS NOT LIABLE FOR CONSEQUENTIAL OR SPECIAL DAMAGES OF ANY NATURE OR KIND RESULTING FROM THE USE OF ANY OF ITS PRODUCTS. OWNERS AND USERS OF DMC PRODUCTS ASSUME FULL

RESPONSIBILITY FOR INSTRUCTING THEIR EMPLOYEES IN THE PROPER AND SAFE USE OF SUCH PRODUCTS.

Daniels Manufacturing Corporation warrants each new unit sold by it to be free from defects in material and workmanship under normal use and service. Its obligation under this warranty is limited to the free correction or, at its option, the refund of the purchase price of any such unit which proves defective within ninety (90) days

after delivery to the first user, provided that the unit is returned with all transportation charges prepaid, and which shall appear to its satisfaction, upon inspection by it, to

have been defective in material or workmanship. This warranty shall not cover any damage to such products, which in the opinion of Daniels Manufacturing Corporation, was caused by normal wear, misuse, improper operation or accident. This warranty is in lieu of all other warranties express or implied. No warranty, express or implied, is made or

authorized to be made or assumed with respect to products of Daniels Manufacturing Corporation, other than that herein set forth.

*as defined by PL93-637