

Twist-Strip™

TSK8000

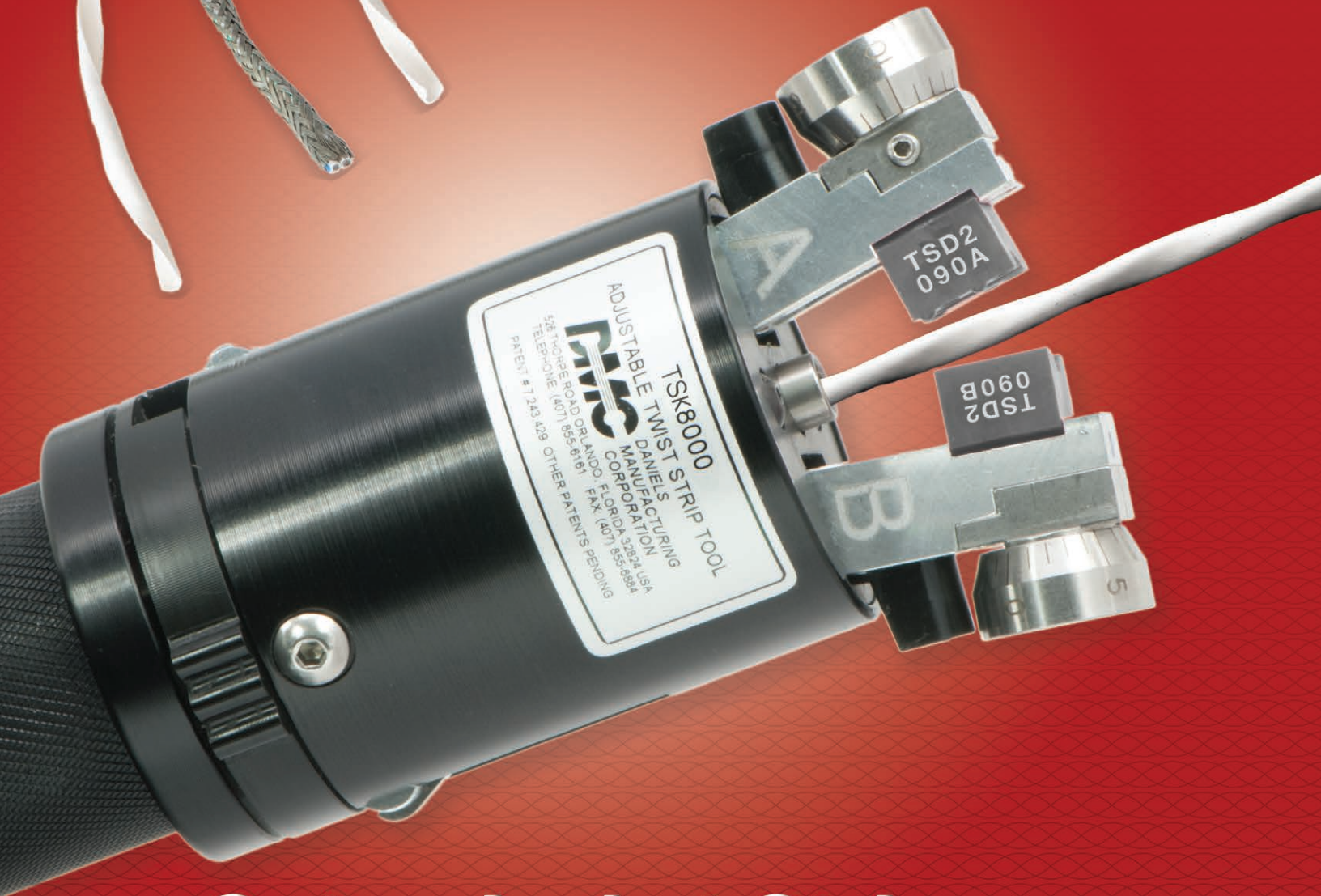

**Outer Jacket Stripper
For Shielded Twisted Cable**

Safe, Accurate, and Repeatable

The Problem

It is common for high-speed data cable to utilize two or more shielded twisted conductors. This type of cable is common in all digital electronic networks, and it requires new tooling disciplines. The challenge in designing a wire prep system of this type is the non-circular configuration of the cable, and the many types, variations, and stripping nuances of shielded, twisted, multi-wire cable.

Imprecise Methods

Stripping multi-conductor wire cable is often done by hand with a razor blade. This is a dangerous and difficult way to remove the jacket from any type of electrical cable. A razor blade offers no method of controlling the depth of cut which will result in a poor quality strip, and cuts or scrapes on the shielding which lead to poor electrical bond and a likely place for corrosion.



Risk of Injury

Using a razor blade increases the probability of injury to the operator and constant tugging to remove the outer jacket which causes operator fatigue. Other methods for removal of the jacket like laser or thermal stripping produce hazardous work environments.

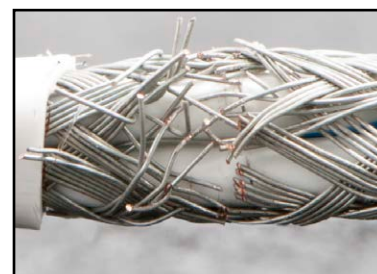

Time Consuming

The conventional “ring and slit” method for stripping shielded twisted cable is very time consuming and requires a highly skilled operator to successfully perform.

The Solution

The DMC Twist-Strip product line gives the user a system with the maximum capabilities, while keeping the system portable, self-contained, affordable, and ergonomic. The precise blade adjustment, zero friction ball bearing design, articulating/locking arms, and changeable dies makes the Twist-Strip very user-friendly and efficient when performing the difficult task of cable preparation.

Adjustable (*New Feature*)

The TSK8000 has adjustable blades that allow the tool to accommodate variances in the cable. Varying jacket thickness and cable diameter are two examples of common differences you may see in different lots of the same cable. Simple adjustments allow the user to set the cutting blades for a deeper or shallower score of the cable jacket.



Precise

A cable track precisely machined into each die set creates a controlled rotation of the dies/blades as the cable is moved along the cable. A simple 90° bend of the cable results in the jacket halves separating for removal, reducing the amount of force needed to remove the jacket.

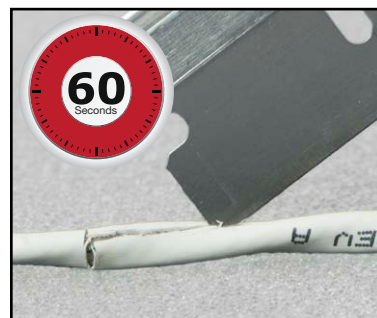

Consistent

The repeatable function of the tool reduces operator error and is up to 3 to 5 times faster than conventional methods.

Operation Overview



1 Arms/Dies Open with Cable Inserted to an Adjustable Stop



.020"-.093"*

2 Adjustable Blade Depth Feature

(Controlled blade adjustment for deeper or more shallow cut)

*Single side movement



3 Arms/Dies Closed on Cable (Ready to Cycle)

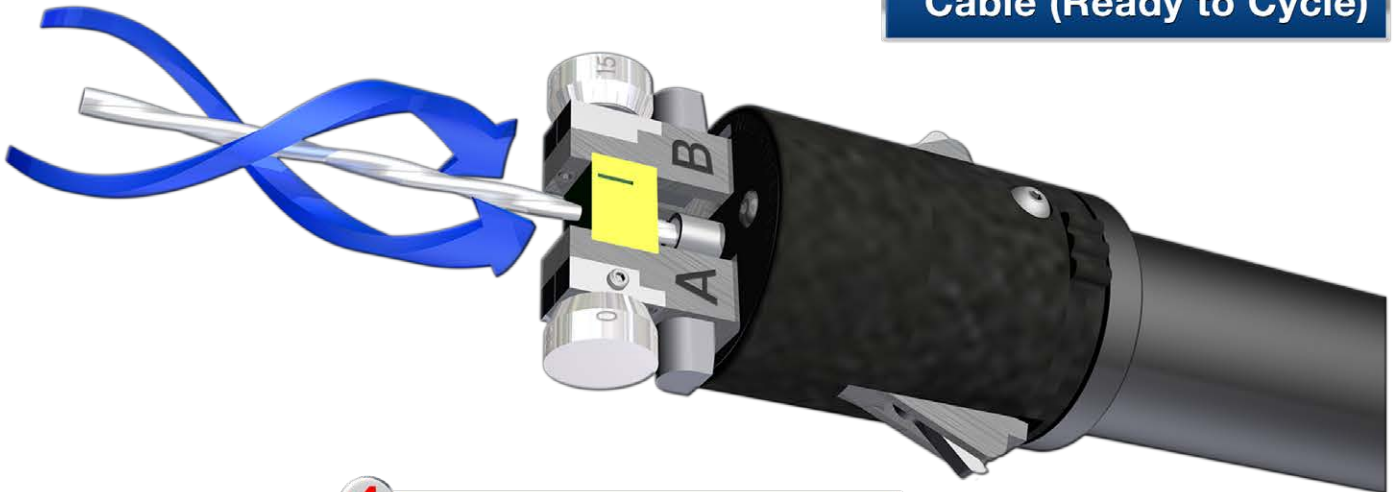

4 Stripping by Pulling Tool

(Score outer jacket to a safe depth)

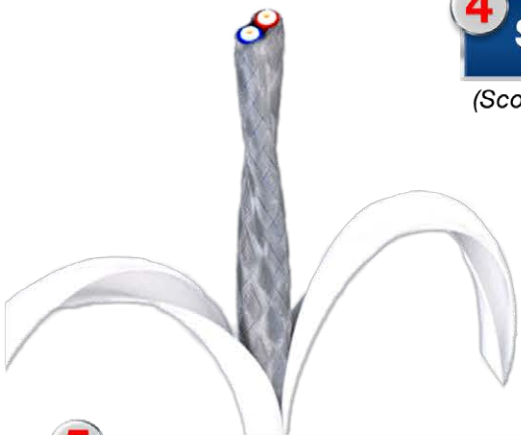

5 Separation of Outer Jacket Segments

A typical two conductor cable is shown. Variations may occur with other cable types. Consult DMC for details.



6 Completed Wire Prep

Die Set Selection

TSK8000 Twist-Strip Outer Jacket Stripping Tool Die Set Part Numbering System - 1 Inner Conductors				
Tool Frame PN	Die Set PN	# of Inner Conductors	Cable OD Range	Cable Lay
TSK8000	TSD1070	1	.061 to .070"	Left Lay
TSK8000	TSD1080	1	.071 to .080"	Left Lay
TSK8000	TSD1090	1	.081 to .090"	Left Lay
TSK8000	TSD1100	1	.091 to .100"	Left Lay
TSK8000	TSD1110	1	.101 to .110"	Left Lay
TSK8000	TSD1120	1	.111 to .120"	Left Lay
TSK8000	TSD1130	1	.121 to .130"	Left Lay
TSK8000	TSD1140	1	.131 to .140"	Left Lay
TSK8000	TSD1150	1	.141 to .150"	Left Lay
TSK8000	TSD1160	1	.151 to .160"	Left Lay
TSK8000	TSD2170	1	.161 to .170"	Left Lay
TSK8000	TSD2180	1	.171 to .180"	Left Lay

Cable Measurement Method One Conductor

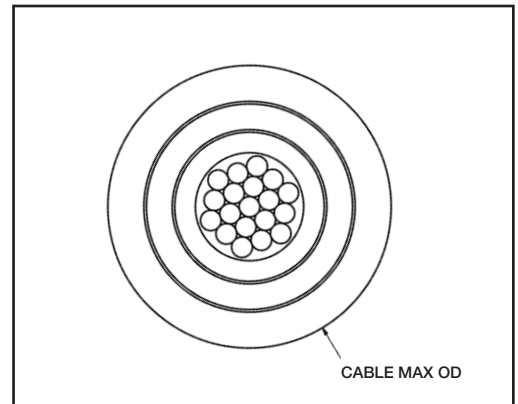

TSK8000 Twist-Strip Outer Jacket Stripping Tool Die Set Part Numbering System - 2 Inner Conductors				
Tool Frame PN	Die Set PN	# of Inner Conductors	Cable OD Range	Cable Lay
TSK8000	TSD2090	2	.081 to .090"	Left Lay
TSK8000	TSD2100	2	.091 to .100"	Left Lay
TSK8000	TSD2110	2	.101 to .110"	Left Lay
TSK8000	TSD2120	2	.111 to .120"	Left Lay
TSK8000	TSD2130	2	.121 to .130"	Left Lay
TSK8000	TSD2140	2	.131 to .140"	Left Lay
TSK8000	TSD2150	2	.141 to .150"	Left Lay
TSK8000	TSD2160	2	.151 to .160"	Left Lay
TSK8000	TSD2170	2	.161 to .170"	Left Lay
TSK8000	TSD2180	2	.171 to .180"	Left Lay

Cable Measurement Method Two Conductor

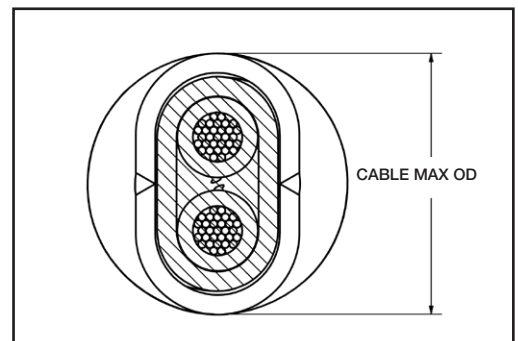

TSK8000 Twist-Strip Outer Jacket Stripping Tool Die Set Part Numbering System - 3 Inner Conductors				
Tool Frame PN	Die Set PN	# of Inner Conductors	Cable OD Range	Cable Lay
TSK8000	TSD3090	3	.081 to .090"	Left Lay
TSK8000	TSD3100	3	.091 to .100"	Left Lay
TSK8000	TSD3110	3	.101 to .110"	Left Lay
TSK8000	TSD3120	3	.111 to .120"	Left Lay
TSK8000	TSD3130	3	.121 to .130"	Left Lay
TSK8000	TSD3140	3	.131 to .140"	Left Lay
TSK8000	TSD3150	3	.141 to .150"	Left Lay
TSK8000	TSD3160	3	.151 to .160"	Left Lay
TSK8000	TSD3170	3	.161 to .170"	Left Lay
TSK8000	TSD3180	3	.171 to .180"	Left Lay

Cable Measurement Method Three Conductor

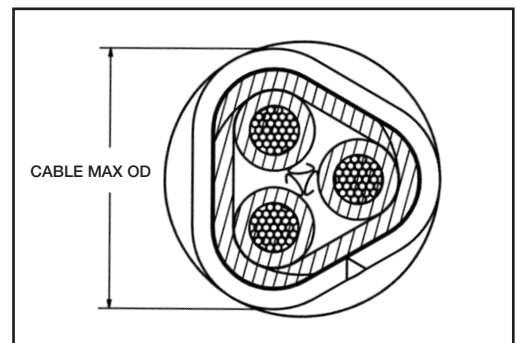

TSK8000 Twist-Strip Outer Jacket Stripping Tool Die Set Part Numbering System - 4 Inner Conductors				
Tool Frame PN	Die Set PN	# of Inner Conductors	Cable OD Range	Cable Lay
TSK8000	TSD4100	4	.091 to .100"	Left Lay
TSK8000	TSD4110	4	.101 to .110"	Left Lay
TSK8000	TSD4120	4	.111 to .120"	Left Lay
TSK8000	TSD4130	4	.121 to .130"	Left Lay
TSK8000	TSD4140	4	.131 to .140"	Left Lay
TSK8000	TSD4150	4	.141 to .150"	Left Lay
TSK8000	TSD4160	4	.151 to .160"	Left Lay
TSK8000	TSD4170	4	.161 to .170"	Left Lay
TSK8000	TSD4180	4	.171 to .180"	Left Lay

Cable Measurement Method Four Conductor

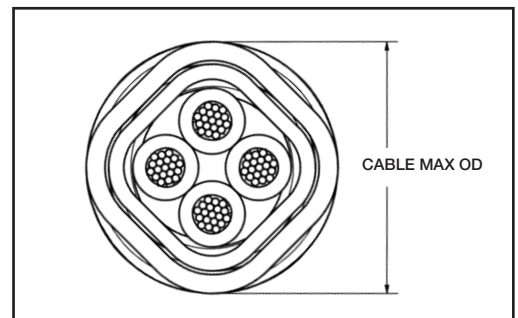

Custom Kits and Projects

DMC works to provide the most comprehensive solutions for high speed data and shielded, twisted, multi-conductor cable preparation.

TSK8000: Twist Strip Kit* with TSK8000 Only

TSK8001: Twist Strip Kit* with TSK8000 w/All (12) 1 Conductor Die Sets (Cable diameter range from 0.061" to 0.180")

TSK8002: Twist Strip Kit* with TSK8000 w/All (10) 2 Conductor Die Sets (Cable diameter range from 0.081" to 0.180")

TSK8003: Twist Strip Kit* with TSK8000 w/All (10) 3 Conductor Die Sets (Cable diameter range from 0.081" to 0.180")

TSK8004: Twist Strip Kit* with TSK8000 w/All (9) 4 Conductor Die Sets (Cable diameter range from 0.091" to 0.180")

TSK8023: Twist Strip Kit* with TSK8000 w/All (20) 2 & 3 Conductor Die Sets (Cable diameter range from 0.081" to 0.180")

**Includes case, TS8000 CIC Cable Diameter Gauge Card, and accessories; in an organized, foam-lined insert. Individual die set part numbers are listed on page 3.*

For certain applications, a custom die set may be required. DMC requests that a 10ft sample of the User's Cable be sent to DMC, and a project will be opened to evaluate and advise, or to design a new die set for the User's cable application. DMC will determine if a standard die set can be used. If there is not a standard die set, DMC will create a new die set for the particular application. DMC will also test standard and custom die sets with the cable that was supplied by the Twist-Strip User to ensure functionality. Please call DMC at (407) 855-6161 or email dmc@dmctools.com for more information.

TS8000-CIC: Cable Diameter Gauge Card

The Cable Diameter Gauge Card should be utilized to select a die set.

The max OD and part number of the appropriate die set are shown next to each opening. Find the smallest opening in the gauge card that the cable freely passes through without getting snagged or stuck.

Select the corresponding die set to strip the selected cable.

NOTE: If the cable passes through the opening in the gauge card, but scrapes the sides of the ID of the opening or gets stuck, the user should select the next larger diameter die set.

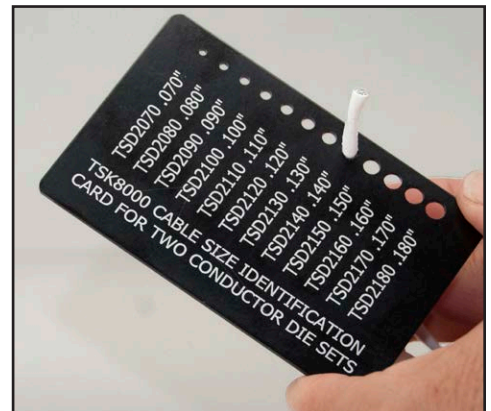

Lay of Cable

Left Hand Lay
"S" Direction

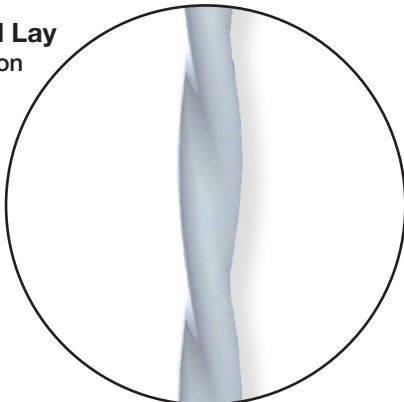

Right Hand Lay
"Z" Direction

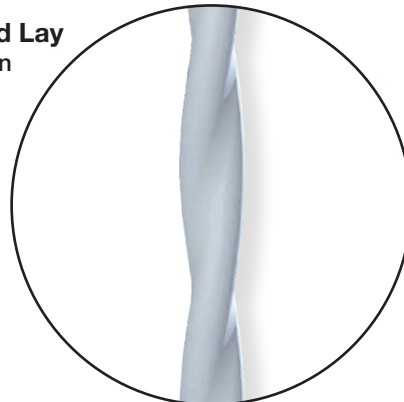

Notes and Specifications

IMPORTANT NOTES

- The “starting depth” for blade adjustment produces a very light score on cable jacket. Operator should adjust cutting depth to preferred depth setting.
- 3 conductor die sets have a non-concentric shape. Therefore, 3 conductor die sets come with only 1 blade. The blade is in the “B” side die. This will produce a single cut longitudinally on the cable.
- Tool allows for .001” incremental adjustments to blade cutting depth.
- Cutting blade depth adjustments are critical for correct performance. Cutting too deep into the cable will damage it beyond repair. Small incremental adjustments reduce potential damage.
- Cable diameter and the # of inner conductors is critical to tool performance. Die sets should be matched to proper cable diameter and # of inner conductors using the chart above.
- In some circumstances a larger die cavity may be needed to accommodate wire that is at the maximum OD for the measured cable part number.
- Universal dies above are designed for cable with a left twist. Dies designed for cable with a right twist have an “R” in the part number: TS**R**XXXX.
- Soft insulation may cause the cable to jam or stick during the stripping operation. Certain applications may not be suited for this tool.
- Certain applications may need a custom die set. If die sets above are not suitable, call DMC at (407) 855-6161 for assistance.

SPECIFICATIONS

Features:

- Rugged lightweight construction
- Adjustable blade depth settings
- Micrometer style blade adjustment knobs.
- Removable and replaceable die sets
- Die Sets have a contoured cable track
- Adjustable cable strip length
- Locking tool arms
- Locking head
- Free rotating core
- Positive die closure



TSK8000 (Kit)
Die Sets Sold Separately

Tool Specifications:

- The TS8000 accommodates a variety of multi-conductor cable having diameters from 0.0625” to 0.180”
- Strips the outer jacket of shielded twisted multi-conductor, and round cable
- End stripping or window stripping of cable as needed
- Interchangeable stripping dies (with cable track and carbide blade set)
- Adjustable blade depth settings
- Tool Weight: .81 lbs
- Shipping Weight: 2lbs (includes entire tool and accessories in foam lined case)
- Die Arm Lever Force: 4.4 lbs
- Die Arm Lever Length: 1”
- Tool Dimensions: 1.75” wide, 9.75” tall
- Cable Max OD: < 0.180”/4.75mm
- Cable Min OD: >0.0625”/1.59mm

NEMA WC 27500 Shielded & Unshielded Cable Part Numbering

(Example: M27500-20SB3T23)

M27500	-	20	SB	3	T	23
SPECIFICATION NUMBER	-	CONDUCTOR SIZE	Basic Wire Specification	NUMBER OF CONDUCTORS	Shield Description	Jacket Type

Jacket Material

Single Jacket	Double Jacket	Jacket Material	Temp. Rating
00	00	No Jacket	-
01	51	Extruded white PVC	90°C
02	52	Extruded clear nylon	105°C
03	53	White polyimide braid impregnated with clear polyimide finisher over a polyester tape	105°C
04	54	Polyester braid impregnated with high temperature finishers over polyester tape	105°C
05	55	Extruded clear FEP	200°C
06	56	Taped PTFE	260°C
07	57	White taped PTFE	260°C
08	58	Extruded white irradiated PVDF	150°C
09	59	Extruded white FEP	200°C
10	60	Extruded clear PVDF	125°C
11	61	Wrapped FEP	200°C
12	62	Tape of natural polyimide combined with FEP wrapped and heat sealed	150°C
14	64	Extruded white ETFE	150°C
15	65	Extruded clear ETFE	150°C
16	66	Taped PTFE	200°C
17	67	Extruded ECTFE	150°C
18	68	Clear Extruded ECTFE	150°C
20	70	Extruded white PFA	260°C
21	71	Extruded clear PFA	260°C
22	72	Tape of polyimide combined with clear FEP wrapped and heat sealed	200°C
23	73	Extruded white irradiated ETFE	200°C
24	74	PTFE wrapped over a tape layer of natural polyimide combined with FEP and heat sealed	200°C