

DANIELS WA27F PNEUMATIC CRIMP TOOL

DMC DANIELS
MANUFACTURING
CORPORATION
DATASHEET

SEE PAGE 3 FOR IMPORTANT INFORMATION CONCERNING
LIMITED WARRANTY, AND LIMITATION OF LIABILITY.

ACCESSORIES, GAGING PROCEDURES AND SPECIFICATIONS

GENERAL SPECIFICATIONS

- * Pneumatic Tools are designed with up to 8 die closures, changeable by a selector knob. The tools also have a full cycle ratcheting control mechanism.
- * Either the hand operated valve or the air foot valve may be used. The working pressure of the tool is 80–120 PSI. It is recommended that each tool be set up with a Filter and Regulator (WA27RF).
- * All Crimping Tools, Positioning Heads, Bench Mounts, Gages and Foot Valves must be ordered by part number.

SIZE

Length: 10" Width: 2.75" Weight: 3.1 lbs.

CRIMPING RANGE

CONTACTS: Size 12 thru 20.

WIRE SIZE: Size 12 AWG thru 26 AWG.

ACCOMMODATIONS

Tool will accommodate all Turret Heads and Single Position Heads relating to Daniels hand tool part number AF8.

FOOT VALVE OPERATION

Attach Foot Valve between air supply and tool air inlet. Depress hand valve and lock in down position with set screw (A) using 1/16 hex Allen® wrench.

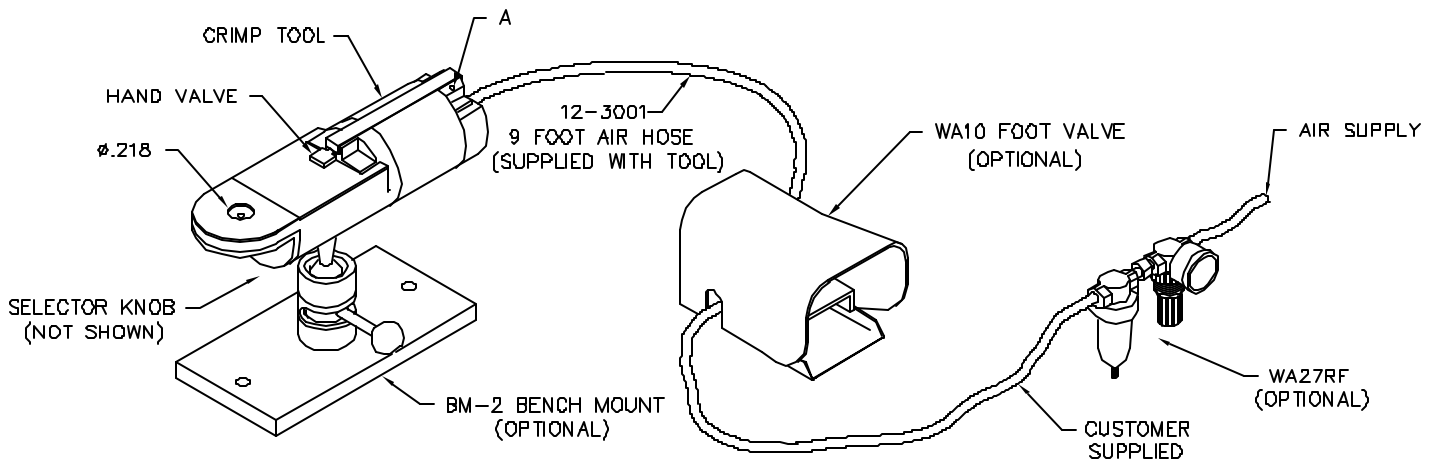

DANIELS MANUFACTURING CORP., 526 THORPE ROAD, ORLANDO, FL 32824, USA, PHONE 407/855-6161, FAX 407/855-6884
COPYRIGHT © 2000 DANIELS MANUFACTURING CORP., USA. WWW.DMCTOOLS.COM E-MAIL: DMC@DMCTOOLS.COM ALL RIGHTS RESERVED

CAUTION!
DO NOT CRIMP GAGE!

GAGING INSTRUCTIONS

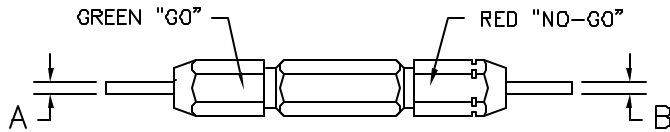

"GO" GAGING

Operate tool to fully closed position. Insert "GO" gage end as shown. Gage must pass freely between indenter tips.

GAGE PART NO.	A GO DIA	B NO-GO DIA	SELECTOR NO.
G125	.0390	.0440	4

"NO-GO" GAGING

Operate tool to fully closed position. Insert "NO GO" gage end as shown. The "NO GO" may partially enter the indenter opening, but must not pass completely through the opening.

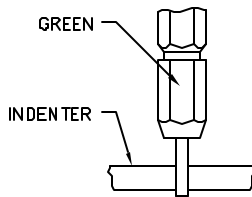

SELECTOR NO.	A ±.0001 GO DIA	B ±.0001 NO-GO DIA
1	.0280	.0330
2	.0320	.0370
3	.0360	.0410
4	.0390	.0440
5	.0450	.0500
6	.0520	.0570
7	.0590	.0640
8	.0680	.0730

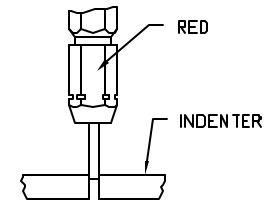

CHECKING THE FULL CYCLE RATCHETING MECHANISM

The ratcheting mechanism can be checked for proper functioning by the following procedure.

1. Adjust the air line pressure to 15 p.s.i.
2. Using a size 20 contact with a size 20 AWG wire, operate the tool until the indenters stop. The indenters will not reach the fully closed position and the contact will be locked in if the ratcheting mechanism is functioning properly.
3. To release the partially crimped contact, increase the air line pressure to 80–120 p.s.i. and operate. The tool will then complete the crimp allowing the indenters to return to the fully open position.

RELEASING A PARTIALLY CRIMPED CONTACT

To release a partially crimped contact, proceed as follows:

1. Increase the air pressure to 120 p.s.i. and operate the unit. If increasing the air pressure does not release the contact, proceed to step 2.
2. Turn the selector knob clockwise to the highest lockable setting. Selector knob must be in the locked position before proceeding. Cycle the unit.
3. If release has not been achieved after several attempts, contact DMC Service Department.

CARE OF TOOL

There is virtually no maintenance required. However, it is a good practice to keep indenter tips free of residual color band deposits and other debris. A small wire brush may be used for this purpose.

We strongly recommend that you:

1. DO NOT immerse tools in cleaning solution.
2. DO NOT spray oil into tool to lubricate.
3. DO NOT attempt to disassemble tool or make repairs.

This is a precision crimping tool and should be handled as such.

DANIELS offers complete refurbishing and recalibration services.

DANIELS specially engineers and manufactures complete tool kits to satisfy individual customer requirements, such as total aircraft support, general shop maintenance or production, on board ship and vehicle service, etc.

LIMITATION OF LIABILITY

DANIELS MANUFACTURING CORPORATION IS NOT LIABLE FOR CONSEQUENTIAL OR SPECIAL DAMAGES OF ANY NATURE OR KIND RESULTING FROM THE USE, OR MISUSE, OF ANY OF ITS PRODUCTS. OWNERS AND USERS OF DMC PRODUCTS ASSUME FULL RESPONSIBILITY FOR INSTRUCTING THEIR EMPLOYEES IN THE PROPER AND SAFE USE OF SUCH PRODUCTS.

LIMITED WARRANTY

DMC (Daniels Manufacturing Corporation) warrants each new product sold by it to be free from defects in material and workmanship under normal use and service. DMC's obligation under this warranty is limited to the free correction or, at DMC's option, the refund of the purchase price of any such product which proves defective in normal service within ninety (90) days after delivery to the first user, provided that the product is returned to DMC with all transportation charges prepaid and which shall appear to DMC's satisfaction, after DMC's inspection, to have been defective in material or workmanship, it being understood that DMC products are not consumer products. This warranty shall not cover any damage to any product which, in the opinion of DMC, was caused by normal wear, misuse, improper operation, tampering, neglect or accident. This warranty is in lieu of all other warranties express or implied. No warranty, express or implied, is made or authorized to be made or assumed with respect to products of Daniels Manufacturing Corporation other than those herein set forth.